



# BLADE RANGE

## DIMMABLE OPTIONS FOR AESTHETICS LIGHTING BLADE

### Digital or Analogue

There are two types of signals that can control dimming operations, Digital and Analogue.

An Analogue signal can be received by a non-digital ballast/transformer (e.g. magnetic ballast or low voltage electronic transformers)  
Dimming in conjunction with magnetic ballasts, works by regulating the voltage, whereas dimming by electronic transformers works by affecting either the trailing or leading edge of the current. The majority of modern transformers dim by both trailing and leading edge methods however it always pays to double check compatibility.  
An analogue signal is used with a rotary dimmer and is compatible with most of the intelligent dimming systems most likely to be encountered in New Zealand. (see table below)

A Digital signal is received by electronic ballasts, and dimming works by the ballast receiving a command to reduce the voltage supplied to the fitting.  
A digital signal is used in switch dim, DSI and DALI dim applications.  
Digital dimming is compatible with several dimming systems most likely to be encountered in New Zealand (see table below)

*\*As a standard Aesthetics Manufacturing use electronic ballasts for fluorescent units and electronic transformers (with analogue signal) for halogen options*

*\*\* Electronic ballasts effectively produce a longer lamp life through providing a warm or soft start for the lamp and by reducing the fluctuations in the voltage which cause flickering. They also offer greater energy efficiency and flexibility.*

### Dimming Protocols

The dimming protocol is the signal / language use to communicate between the dimming controller / system and the ballast of the fitting.

1. Non dim                      Electronic or Low loss magnetic ballasts
2. Rotary dim                 Analogue ballasts  
Or Dimmable electronic ballasts with analogue/digital converter
3. Switch dim                 Dimmable electronic ballasts
4. DSI dim                     Dimmable electronic ballasts (need to be DSI compatible)  
*(Converters available)*
5. DALI dim                    Dimmable electronic ballasts (need to be Dali compatible)  
*(converters available)*

## **Dimming Systems**

The dimming system / controller, is where the programming occurs. Dimming levels, timing and scenes can be set.

- I. Graffik eye                -Requires an analogue signal  
Analogue ballasts  
Or Dimmable electronic ballasts with analogue/digital converter  
(Audio Video Designs)
- II. Dynalite                    Dimmable electronic ballasts or Analogue ballasts  
(MJF Lighting)
- III. Cebus                     Dimmable electronic ballasts or Analogue ballasts  
(PDL)
- IV. Luxmate                   Dimmable electronic ballasts or Analogue ballasts  
(Zumtobel)

*-It is strongly recommended that different lamp types are kept on separate circuits.*

*-As always there are some exceptions and alternative ways of doing things please always double check to ensure compatibility of product and system if in doubt, as supplementary components may be required.*

*-This is not an exhaustive list. Always check what system is controlling the dimming and what dimming protocols are compatible.*

## T5 Fluorescent dimming options

### 1. Non Dim

- As standard, Blade is wired with non-dimmable electronic ballasts.
- Options for light levels are either full on or full off
- Three core flex required
- For wiring information see Pic. 1 and Pic. 2.

### 2. Analogue Dim (Rotary dimming)

- Analogue dimming allows for on, off and dimming up and down.
- As standard, wired with dimmable electronic ballasts with analogue / digital converter (*must be specified!!*)
- For trailing or leading edge dimming – with rotary dimmer
- Several fittings can be linked on a circuit to one dimmer for synchronized dimming (*maximum load refer to rotary dimmer specifications*)
- When turned off and on, light level stays at whatever level it was left at when it was turned off.
- 4 core flex required
- Compatible with Grafik eye, Dynalite, Cebus and Luxmate systems.

*\*Analogue ballasts are available however there is a lead time for this option and pricing is available on request.*

### 3. Digital Switch Dim

- Switch dim allows for on, off and dimmed settings.
- Synchronised dimming can be achieved with multiple fittings.
- The digital electronic ballast used can easily be upgraded to work with DSI systems. Can upgrade to DSI without any major wiring (*as long as it is initially wired with a five core flex*). (*Depending on the ballast used upgrading to DALI may also be possible.*)
- Dimmed level is retained in the ballast's memory when the power is off via the switch dim mechanism however is lost when the mains power is cut to the system.
- Dimming range – see manufacture's specifications on ballast.
- The polarity of the live and neutral wires needs to be consistent within a switch dim circuit containing multiple ballasts.
- While a four core flex is the minimum wiring required, Aesthetics Manufacturing will provide a five core flex with switch dim units for standardisation and flexibility.
- For wiring see Pic. 3 - 6.

### 4. Digital Serial Interface (DSI) Dim

- For synchronised dimming and scene control.
- Can create and save different lighting scenes to be programmed within an environment.
- Daylight sensors can be added for greater energy efficiency.
- Requires an uninterrupted power feed to the ballast at all times to keep its memory – otherwise when next switched on it will turn to full power.\* *(the Atco PCA one4all ballast is an exception which includes a memory even when power is cut).* The residual current is drawn through the system controller.
- 5 core flex required.
- For wiring see Pic. 7

*\*Even when the luminaries are 'off' electrical current is still present. It is recommended to have an isolating switch on the wall or in the ceiling tile to allow for safe maintenance work.*

## 5. Digital Addressable Lighting Interface (DALI) Dim

- Allows for synchronised dimming, scene control and programmable lighting environments.
- For wiring and Ballast conditions see DSI dimming.
- Luminaries / ballasts can be programmed individually.
- Greater energy efficiency can be achieved by the use of environment sensors within a DALI system.
- 5 core flex required.
- For wiring see Pic 7

## **Halogen downlight dimming options**

Analogue trailing or leading edge

- check compatibility of trailing or leading edge dimming units.
- Rotary dim pots only.
- Use only high quality lamps as some lamps have a tendency to hum when dimmed due to the quality of the filament construction.
- Blade downlights supplied with Atco or Vossloh electronic transformers

Digital dim

- With and Atco one4all transformer, low voltage halogens can be compatible with switch dim, DSI and DALI protocol.
- With RHUN unit (Marexim) converter accessory for 12v electronic transformers. Each RHUN unit can handle up to a 300w resistive load in a switch dim circuit.

## **Grafik Eye Dimming System**

- The Grafik eye system (3000 series) from Lutron requires an analogue signal for operation (refer pg 3). *(With the exception of the Integrale unit)*

- When used in conjunction with the Aesthetics Blade range a digital/analogue converter must be specified with the standard digital dim ballast. (An analogue ballast can be used however it is not the standard supplied)
- Requires an uninterrupted power feed to the ballast at all times to keep its memory – otherwise when next switched on it will turn to full power. The residual current is drawn through the system controller.
- The Grafik eye allows for stand alone operation of circuits and scene control.
- Daylight sensors and other electronic products (such as stereos) can be added to the system
- Up to eight Grafik eye's can be connected together for larger systems (max 16 accessories per system)
- A TVI interface is required for each fluorescent circuit in a Grafik eye system. (TVI unit requires it's own 230v power supply)
- The Integrale unit (4 circuit version only) has an integral fluorescent interface and is compatible with digital dim ballasts – no converter is required.
- A 5 core flex for dimmable ballasts required from fittings.
- No special wiring is needed between the fitting and the system and components
- Standard Cat. 5 data cable is required between Grafik eye components. (such as slave panels)

*\*Even when the luminaries are 'off' electrical current is still present. It is recommended to have an isolating switch on the wall or in the ceiling tile to allow for safe maintenance work.*

# Wiring Diagrams

## Standard Wiring for non-dim ballast

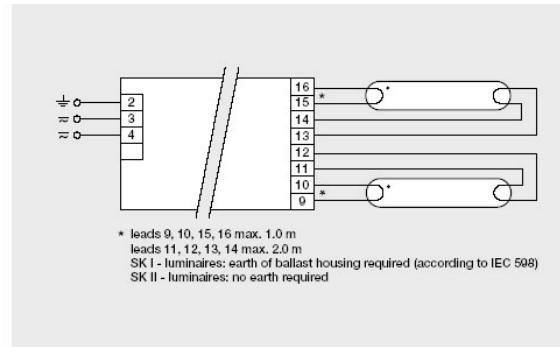
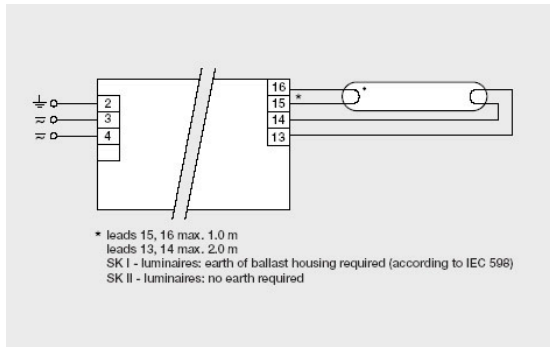

Pic 1. Wiring with one lamp configuration (Atco PC T5 Pro ballasts.)

Pic 2. Wiring with two lamp configuration

## Wiring for switch dim

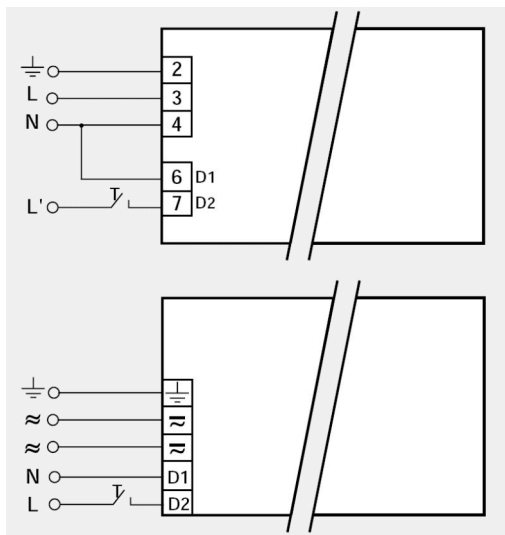

Pic 3. Wiring with 4 core flex

Pic 4. Wiring with 5 core flex

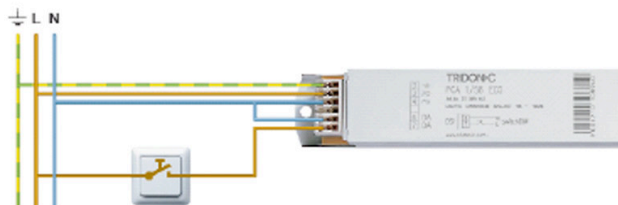

Pic 5. SwitchDIM with one operation point

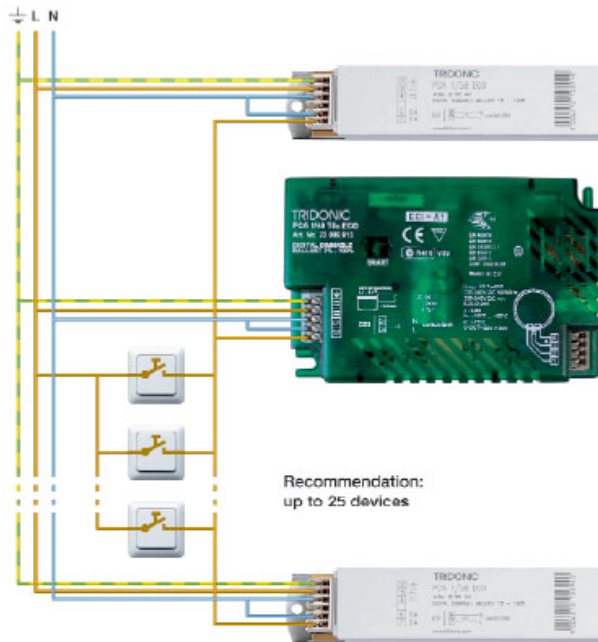

Pic. 6. SwitchDIM with several operation points

Switch dim, DSI and DALI dimming allow for the operation of several ballasts and/or fittings to be run off the same control unit. As shown above, several switches can also be included and controlled by one unit.

### Wiring for DALI and DSI dim ballasts

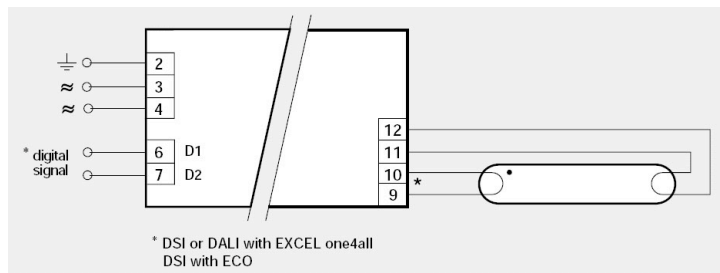

Pic. 7. DSI and Dali wiring diagram with 5 core flex